

DIN 238, Kegeldorne mit Morsekegelschaft

DIN 238, kuželové trny se stopkou s Morse kuželem



Ganz gehärtet und geschliffen
Plně kalená a broušená

MK / MT	Kegel / Kužel	L mm	ca. g	Art.-Nr. / Obj. č.	EUR
1	B 10	86	55	● 41-1/B10	3,30
1	B 12	90	60	● 41-1/B12	3,40
1	B 16	97	90	● 41-1/B16	3,40
1	B 18	105	110	● 41-1/B18	3,50
1	B 18 VK	97	95	* 41-1/B18VK	4,40
2	B 10	101	130	● 41-2/B10	3,30
2	B 12	105	135	● 41-2/B12	3,40
2	B 16	112	160	● 41-2/B16	3,40
2	B 18	120	180	● 41-2/B18	3,60
2	B 18 VK	108,5	165	* 41-2/B18VK	4,20
2	B 22	128	245	● 41-2/B22	5,00
3	B 12	124	280	● 41-3/B12	4,50
3	B 16	131	310	● 41-3/B16	4,50
3	B 18	139	320	● 41-3/B18	4,70
3	B 18 VK	132	320	* 41-3/B18VK	6,30
3	B 22	147	390	● 41-3/B22	4,70
3	B 24	157	440	● 41-3/B24	8,20
4	B 16	156	625	● 41-4/B16	8,40
4	B 18	164	660	● 41-4/B18	8,40
4	B 18 VK	159	640	* 41-4/B18VK	12,20
4	B 22	172	715	● 41-4/B22	10,50
4	B 24	182	770	● 41-4/B24	11,10
5	B 16	188	1600	● 41-5/B16	20,40
5	B 18	196	1600	● 41-5/B18	21,20
5	B 22	204	1650	● 41-5/B22	22,00
5	B 24	214	1700	● 41-5/B24	22,90

VK = verkürzter Bohrfutterkegel
VK = zkrácený kužel vrtacího sklíčidla

Kegeldorne mit Zylinderschaft

Kuželové trny s válcovou stopkou

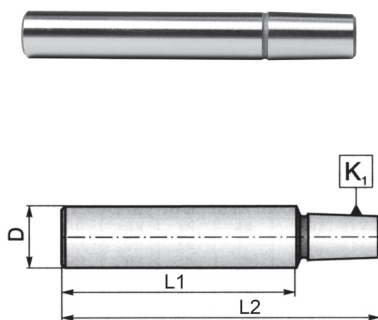

Ganz gehärtet und geschliffen
Plně kalená a broušená

D mm	L1 mm	Kegel / Kužel	L2 mm	Art.-Nr. / Obj. č.	EUR
8	35	B 10	55	● 13-5348-8-35-B10	9,10
10	50	B 10	70	● 13-5348-10-50-B10	9,10
10	50	B 12	75	● 13-5348-10-50-B12	9,10
10	50	B 16	82	● 13-5348-10-50-B16	10,50
12	50	B 16	82	● 13-5348-12-50-B16	10,50
12	60	B 16	92	● 13-5348-12-60-B16	10,50
16	50	B 16	81	● 13-5348-16-50-B16	10,50
16	70	B 16	101	● 13-5348-16-70-B16	10,50
16	70	B 18	110	* 13-5348-16-70-B18	10,50
20	60	B 12	87	● 13-5348-20-60-B12	13,10
20	60	B16	93	● 13-5348-20-60-B16	13,10
20	60	B 18	100	● 13-5348-20-60-B18	13,10
25	75	B 16	107	● 13-5348-25-75-B16	13,10
30	70	B 16	106	* 13-5348-30-70-B16	13,10
30	70	B 18	112	* 13-5348-30-70-B18	13,10