

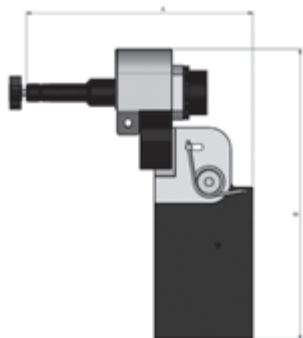

Automatische Schleifvorrichtung für Innen- und Stirnflächen
Automatic grinding device for face and internal grinding

- zum Einspannen in Drehstahlhalter
 - zum Schleifen und Entgraten von Innen- und Stirnflächen
 - Schleiffächer und Schleifteller mit Schaftdurchmesser 6 mm
- for use in quick-change tool holders
 - for sanding and refining of internal and frontal surfaces
 - for use with rotating abrasive tool and disc with 6 mm shank



A mm	B mm	Aufnahme / Mounting mm	Art.-Nr. / Order no.
207	267	Ø 6	<input checked="" type="checkbox"/> ZE-AXS-01



Schleiffächer
Rotating abrasive tool

Durchmesser / Diameter mm	Körnung / Grain	Art.-Nr. / Order no.
30	60	<input checked="" type="checkbox"/> ZE-ASF-30/60
40	60	<input checked="" type="checkbox"/> ZE-ASF-40/60
40	120	<input checked="" type="checkbox"/> ZE-ASF-40/120
40	120	<input checked="" type="checkbox"/> ZE-ASF-40/240



Schleifteller
Abrasive disc

Durchmesser / Diameter mm	Art.-Nr. / Order no.
60	<input checked="" type="checkbox"/> ZE-AST-60



Schleifplatte *
Sanding pad *

Durchmesser / Diameter mm	Art.-Nr. / Order no.
60	<input checked="" type="checkbox"/> ZE-ASA-60

* Preis pro Stück. Abgabe nur in VE à 10 Stück
 * Price per piece. Only available in sets of 10 pieces