

# Dreibacken-Kraftspannfutter mit großer Durchgangsbohrung - 1,5 x 60°

## Three-jaw power chucks with big bore - 1,5 x 60°

1  
1.10

DIN 55026, mit großer Durchgangsbohrung  
According to DIN 55026, with big bore

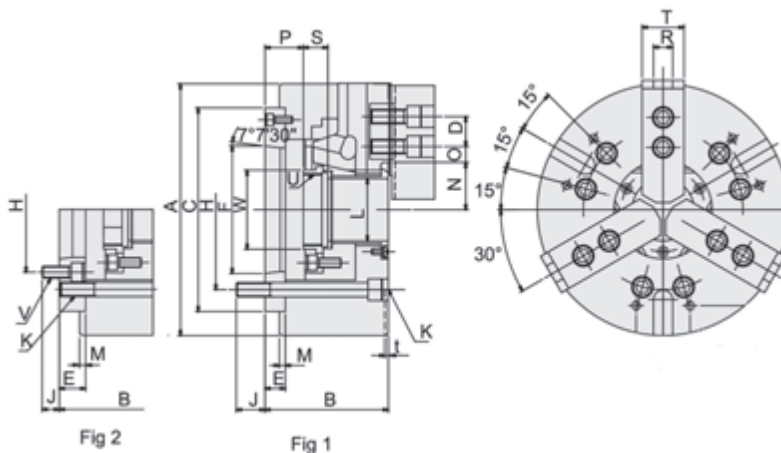
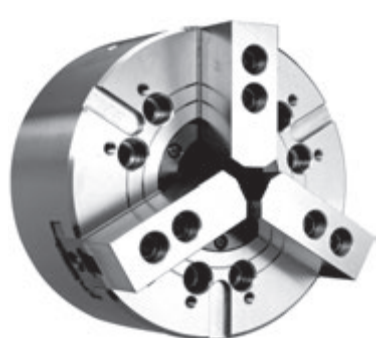

### Stahl / Steel

Typ / Type	Backenhub / Jaw stroke mm	Zugrohrhub / Plunger stroke mm	Max. Betätigungskraft / Max. Draw bar pull force (kN)	Max. Spannkraft / Max. gripping force (kN)	Max. Betätigungsdruck / Max. operating pressure (kN)	Passende harte Aufsatzbacken / Matching hard jaws	Passende weiche Aufsatzbacken / Matching soft jaws	Passender Zylinder / Matching Cylinder	Max. Drehzahl / Max. speed (rpm)	kg	Art.-Nr. / Order no.
NB-206A5	6	12	22	57	18	HJ06	HC06	RCS-8	6000	14,5	● T9-NB-206A5
NB-208A6	7,4	17	34,89	89	18	HJ08	HC08	RCS-10	4600	24,5	● T9-NB-208A6
NB-210A8	8,8	19	43	111	19,5	HJ10	HC10	RCS-10	4200	37,4	● T9-NB-210A8
NB-212A8	8,8	19	43	111	19,5	HJ12	HC12	RC-15	3300	61	○ T9-NB-212A8
NB-212A11	10,6	23	57	147	20,5	HJ12	HC12	RC-15	3300	61	○ T9-NB-212A11

Inkl. je 1 Satz Grund- und weiche Aufsatzbacken, Befestigungsschrauben, Zugrohradapterrohling  
Incl. 1 set each of hardened base jaws and soft top jaws, fixation screws, blank draw tube adaptor

Typ / Type	A mm	B mm	C mm	D mm	E mm	F mm	H mm	J mm	K	L mm	M mm	O max.	O min.	P max.	P min.	t mm	R mm	S mm	T max.	T min.	U max	V	W mm
NB-206A5	175	75	140	20	30	82,563	104,78	16	6xM10	52	5	24	7,5	25	12,5	5	12	19	32	M60x2,0	6xM16	60	
NB-208A6	215	103	170	25	22,5	106,375	133,35	16	6xM12	66	7	25,5	18,5	12,5	4	5	14	25	37	M74x2,0	6xM16	80	
NB-210A8	254	113	220	30	18	139,719	171,45	20	6xM16	78	5	34,5	12	24,5	7,5	5	16	25	42	M87x2,0	6xM16	94	
NB-212A8	318	137	300	30	33	139,719	171,45	20	6xM20	110	6	53,5	19	37	14	5	21	28	52	M115x2	6xM16	94	
NB-212A11	318	126	300	30	22	196,8	235	20	6xM20	210	6	53,5	19	26	3	5	21	28	52	M115x2	6xM16	143	

Backen kompatibel zu Kitagawa Typ BB200  
Jaws compatible with Kitagawa type BB200

Kraftspannfutter, Backen und Zubehör / Power chucks, jaws and accessories

