

# Hydraulikzylinder mit Durchgang für hohe Drehzahlen Hydraulic high speed cylinders with trough-hole

## Typ M Type M

- kompakte und leichte Bauweise
- große Bohrung
- geeignet für hohe Drehzahlen
- small sized and light-weight design
- large bore
- suitable for high speeds

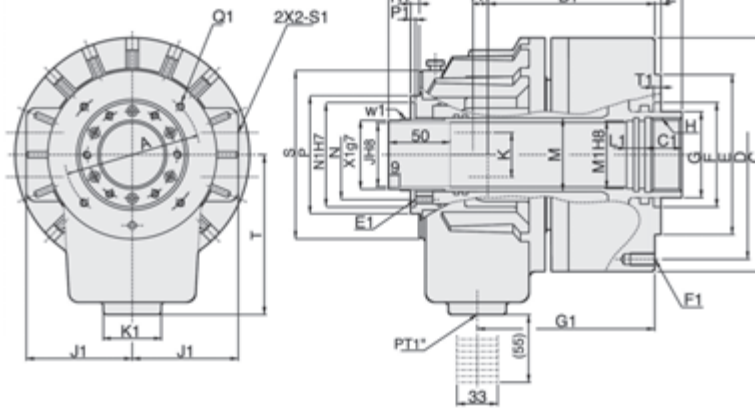

Typ / Type	Kolbendurchmesser / Piston dia mm	Kolbenfläche Druckseite / Piston area Pressure side cm <sup>2</sup>	Kolbenfläche Zugseite / Piston area Pull side cm <sup>2</sup>	Kolbenhub / Piston stroke mm	Max. Zugrohrkraft (öffnen) / Max. draw bar pull-push side kgf	Max. Zugrohrkraft (schließen) / Max. draw bar pull-pull side kgf	Max. Betriebsdruck / Max. operating pressure kgf / cm <sup>2</sup>	Max. Drehzahl / Max. speed	Trägheitsmoment / Moment of inertia kg / m <sup>2</sup>	Gesamtundichtheit / Total leakage L / min	Art.-Nr. / Order no.
4M0928	90	47	41,5	9	19,9 (2029)	18 (1835)	40	8000	0,02	3,0	<input type="radio"/> T9-M0928
5M1036	105	67	64,5	15	24,8 (2529)	24 (2447)	40	8000	0,044	3,0	<input type="radio"/> T9-M1036
6M1246	125	100	89	15	38 (3875)	33 (3365)	40	7000	0,070	3,0	<input checked="" type="radio"/> T9-M1246
8M1552	155	161	150	22	60 (6118)	56 (5710)	40	6200	0,21	3,9	<input checked="" type="radio"/> T9-M1552
10M1875	180	198	183	25	74 (7546)	69 (7036)	40	4700	0,38	4,2	<input type="radio"/> T9-M1875
10M1878	180	198	183	25	74 (7546)	69 (7036)	40	4700	0,38	4,2	<input type="radio"/> T9-M1878
12M2091	205	252	234	30	94 (9584)	88 (8973)	40	3800	0,61	4,5	<input type="radio"/> T9-M2091

Inkl. Kühlmittelsammler  
Incl. coolant collector

Typ / Type	C1 mm	E1 mm	F1 mm	G1 mm	H1 mm	J1 mm	K1 mm	L1 mm	M1 mm	N1 mm	O1 mm	P1 mm	Q1 mm	R1 mm	S1 mm	T1 mm	U1 mm	W1 mm	X1 mm	B mm	C mm
4M0928	25	M6x10	M8x20	114,5	76	60	44	15	30	53	14	4	M4x10	5	PT1/4"	6	116	M34x1,5	32	85	115
5M1036	25	M5x9	M10x20	126,5	88	66	53	15	38	64	14	4	M5x10	5	PT3/8"	6	136	M44x1,5	42	101	135
6M1246	30	M6x9	M10x20	135	98	76	47	15	50	76	14	4	M5x10	6	PT1/2"	6	169	M52x1,5	50	99	155
8M1552	30	M6x9	M10x20	145	110	86	47	15	55	85	14	4	M6x12	7	PT1/2"	6	187,5	M58x1,5	56	103	190
10M1875	35	M6x9	M10x20	166,5	155	101	47	15	80	108	16	4	M6x12	7	PT1/2"	6	220	M84x2	81	126	215
10M1878	35	M6x9	M10x20	166,5	155	101	47	15	80	108	16	4	M6x12	7	PT1/2"	6	220	M84x2	81	126	215
12M2091	35	M6x14	M22x24	183	165	110	47	15	95	120	16	4	M6x12	7	PT1/2"	6	267	M99x2	96	141	240

Typ / Type	D mm	E mm	F mm	G mm	H mm	J mm	K mm	L mm	N mm	P mm	Q mm	S mm	T mm	U max mm	V min mm	V max mm	W min mm	W mm	A1 mm	B1 mm
4M0928	100	80	65	44	M38x1,5	28	25	54	44	59	65	90	105	158	9	0	34	25	9,5	106
5M1036	115	100	65	48	M42x1,5	36	30	62	54	73	80	104	115	175,5	10	-5	46	25	11	120,5
6M1246	130	100	80	65	M55x2	46	36	67	64	85	90	118	115	184	10	-5	40	25	11,5	126,5
8M1552	170	130	85	70	M60x2	52	36	75	73	96	102	137	130	196	17	-5	47	25	12	136
10M1875	190	160	120	95	M85x2	75	36	84	98	121	131	166	160	230	20	-5	50	25	17,5	153,5
10M1878	190	160	120	95	M87x2	78	36	84	98	121	131	166	160	230	20	-5	50	25	17,5	153,5
12M2091	215	180	140	110	M100x2	91	36	93	108	138	148	182	185	253	25	-5	55	25	21	168

